

1008-0070...0260, 1008(WZ/TSL) 型固定尾座  
 1008-0070...0260, 1008(WZ/TSL) TYPE TAILSTOCK

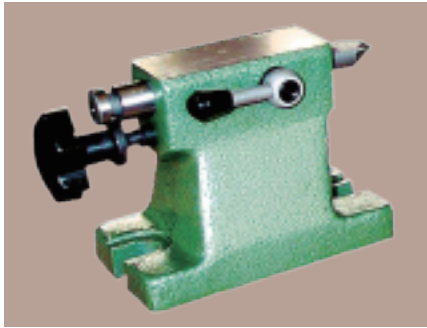

1008(WZ)尾座是TSL系列立卧回转工作台及其它机床附件配套附件之一。它与TSL系列回转工作台及其他机床附件配合使用,可加工用顶尖支撑的轴类工件。

注: 1008-0070(WZ70)尾座配用1003-0100(TSL100)转台, 1008-0070(WZ70)尾座配用1003-0400(TSL400)转台。用户订货时, 配用转台的尾座, 需特别说明。

1008(WZ), 1008-0260 (TSL400-2) is designed for use with the vertical rotary tables. The tailstock is used to hold center shaft, cylinders and other workpieces for the machining of grooves, splines, flats, keyways, etc. The center is retractable for repeated operations. Center is securely locked into position with clamp.

Note: Type 1008-0070(WZ70) tailstock is matched to 1003-0100(TSL100). Type 1008-0260 tailstock is matched to 1003-0400(TSL400). The tailstock for rotary table is special supplied.

主要规格和参数: Main specifications

规格 Specifications	项目 Items	1008-0070 (WZ70)	1008-0260 (TSL400-2)
顶尖锥孔中心至底平面距离	Distance between taper center to base mm	70	260
顶尖套中心孔锥度	Taper of Center	-	MT3
定位键宽度	Width of locating key mm	10	18
顶尖套轴向最大移动量	Stroke of center mm	12	30
净重	Net weight Kg	2.5	28
毛重	Gross weight Kg	3	32
箱体尺寸	Case dimensions mm	200X120X202	375X355X260

1008-0070...0260, 1008(WZ/TSL) 型固定尾座安装尺寸参数

Inatallation sketch and dimensions

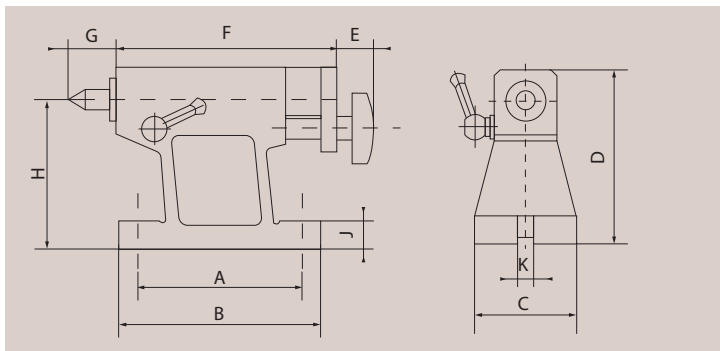

1008-0070, 1008(WZ/TSL)型固定尾座安装尺寸参数: Inatallation sketch and dimensions

	A	B	C	D	E	F	G	H	J	K
1008-0070 (WZ70)	43	110	65	67.56	25	69	25	70	12	10
1008-0260 (TSL400-2)	193	225	150	290	40	216	49	260	28	18