

1013-0100...0800, 1003 (TSL) 系列回转工作台 1003-0100...0800, 1003(TSL) SERIES ROTARY TABLE

1003(TSL)系列回转工作台是铣床的主要附件之一, 可用在铣床上进行分度钻孔或铣削、圆周切削、镗孔铰平面等工作。工作台垂直位置与尾座配合使用时, 还可对较复杂的工件进行圆周分度钻削和铣削。每个规格的转盘分别提供连接不同卡盘的法兰盘, 作为特殊订货, 并将法兰盘独立包装。另外, 为特殊订货所提供的分度盘附件可实现由2至66间所有整数和由67到132间能被2, 3和5整除的所有整数的分度。

THE 1003 (TSL) series horizontal and vertical rotary tables. circular cutting, angle setting, boring, spot facing operations and similar work in conjunction with a milling machine. This type rotary table is designed so as to permit machining operations are at a higher dimension than that of 1001(TS) type rotary table. The base can be used in a vertical position to enable to carry out center work with the help of tailstock.

A flange for connecting scroll chucks are supplied and packed separately. For special order, the dividing plates accessory allows the operator to accurately divide the 360° rotation of the clamping surface into divisions of 2 through 66, and all divisible of 2, 3 and 5 from 67-132.

主要规格和参数: Main specifications

规格 Specifications 项目 Items	1003-0100 (TSL100)	1003-0160 (TSL160)	1003-0200 (TSL200)	1003-0250 (TSL250)	1003-0320 (TSL320)	1003-0400 (TSL400)	1003-0800 (TSL800)
工作台面直径 Diameter of table mm	φ 100	φ 160	φ 200	φ 250	φ 320	φ 400	φ 800
台面中心孔锥度 (莫氏) Morse Taper of the center hole	2#	2#	3#	3#	4#	4#	6#
台面定位孔直径 Diameter of the center hole mm	φ 20X8	φ 25X6	φ 30X6	φ 30X6	φ 40X10	φ 40X10	φ 75X14
工作台垂直时中心高 Height of center for Vertimounting mm	70	125	150	170	210	260	500
台面T型槽宽度 Width of T-slot mm	6	10	12	12	14	14	22
台面T型槽相邻角度 Adjacent angle of T-slot	90°	90°	90°	60°	60°	60°	45°
定位键宽度 Width of locating key mm	10	12	14	14	18	18	22
蜗轮副模数 Modules of worm and worm gear	1	1.5	1.75	2	2.5	3.5	5.5
蜗轮副传动比 Transmission ratio of the worm gear	1: 72	1: 90	1: 90	1: 90	1: 90	1: 90	1: 120
工作台圆周刻度 Graduation of the table	360°	360°	360°	360°	360°	360°	360°
轮台手轮刻度值 Readout of the handwheel	2'	1'	1'	1'	1'	1'	1'
游标最小示值 Minimum value of vernier	10"	10"	10"	10"	10"	10"	10"
分度精度 Indexing accuracy	120"	80"	60"	60"	60"	60"	60"
最大承载 (卧式) Max.bearing(with table Hor.)Kg	20	100	150	200	250	300	1500
最大承载 (立式) Max.bearing(with table Vert.)Kg	10	50	75	100	125	150	750
净重 Net weight Kg	7	23	31.5	46	77	150	--
毛重 Gross weight Kg	8	30	42	57	92	175	1200
箱体尺寸 Case dimensions mm	245X165X112	432X432X220	450X440X235	510X460X240	590X580X250	750X684X286	1247X1222X510
可配卡盘 Maching chuck	K1180	K11125	K11160	K11200	K11250	K11325	K11630A



1003-0100...0800, 1003 (TSL) 系列回转工作台 1003-0100...0800, 1003(TSL) SERIES ROTARY TABLE

1003-0100...0800, 1003(TSL) 系列回转工作台安装尺寸图 Dimensional Sketch

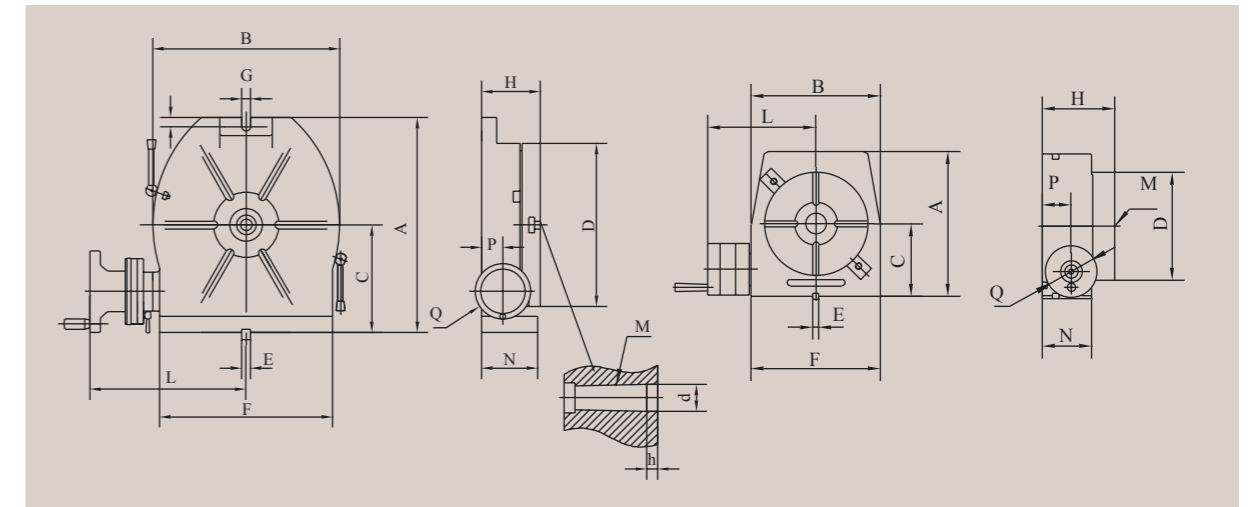

1003-0100...0800, 1003(TSL)系列回转工作台安装尺寸参数: Installation sketch and dimensions

	1003-0100 (TSL100)	1003-0160 (TSL160)	1003-0200 (TSL200)	1003-0250 (TSL250)	1003-0320 (TSL320)	1003-0400 (TSL400)	1003-0800 (TSL800)
A	125	242	285	328	410	525	980
B	125	196	236	286	360	450	890
C	70	125	150	170	210	260	500
D	φ 100	φ 160	φ 200	φ 250	φ 320	φ 400	φ 800
E	10	12	14	14	18	18	22
F	125	186	208	253	320	400	800
G	/	12	14	14	18	18	22
H	70	85	100	110	120	150	300
J	/	12	15	16	16	16	30
L	114	194	211	241	273	337	534
M	MT2	MT2	MT3	MT3	MT4	MT4	MT6
N	48	82	99	106	118	145	295
P	30	37	48	48	48	70	136
Q	50	125	125	125	140	160	250
d	φ 20	φ 25	φ 30	φ 30	φ 40	φ 40	φ 75
h	8	6	6	10	10	10	14