

1035-0030...0050 立卧式装卸器

1035-0030...0050 CNC Tool Holder Fixture

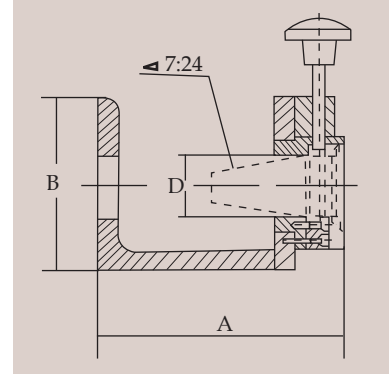

Horizontal/Vertical Positioning
Compact, Efficient Design for Easy
Mounting and Use
Use on CAT and BT Tapers
Secures Toolholder for Maximum Protection
Easy Access of Cutting Tool and Pull Stud



Stock No	Tapper	D	A	B
1035-0030	30	32mm	180mm	130mm
1035-0040	40	44.5mm	180mm	130mm
1035-0045	45	57.2mm	235mm	175mm
1035-0050	50	70mm	235mm	175mm

HITECH (Qingdao)
ENTERPRISES INC