

1001-0160...2500, 1001 (TS) 系列回转工作台
1001-0160...2500,1001(TS) SERIES ROTARY TABLE



1001(TS)系列回转工作台（平转台）是铣床的主要附件之一，可用在铣床上进行分度钻孔或铣削、圆周切削、圆周曲面加工、平面及部分线段的直线加工等工作。

每个规格的转台分别提供连接不同卡盘的法兰盘，作为特殊订货，并将法兰盘独立包装。另外，为特殊订货所提供的分度盘附件可实现由2至66间所有整数和由67到132间能被2，3和5整除的所有整数的分度。

THE 1001 (TS) series horizontal rotary tables are for indexing, circular cutting, angle setting, boring, spot facing operations and similar work in conjunction with a milling machine.

A flange for connecting scroll chuck is special supplied, can be packed independently. For special order, the dividing plates accessory allows the operator to accurately divide the 360° rotation of the clamping surface into divisions of 2 through 66, and all divisible of 2, 3 and 5 from 67-132.

主要规格和参数: Main specifications

规格 Specifications 项目 Items	1001-1600 (TS1600A)	1001-2000 (TS2000A)	1001-2500 (TS2500A)
工作台直径 Table diameter mm	φ 1600	φ 2000	φ 2500
台面中心通孔 Diameter of the through hole	φ 100	φ 120	
台面定位孔直径 Diameter of the center hole mm	φ 120x25	φ 150x30	
台面T型槽宽度 Width of T-slot mm	22	22	22
台面T型槽相邻角度 Adjacent angle of T-slot	22.5°	22.5°	22.5°
蜗轮副模数 Modules of worm and worm gear	8	8	8
蜗轮副传动比 Transmission ratio of the worm gear	1:120	1: 180	1: 180
工作台圆周刻度 Graduation of the table	360°	360°	360°
蜗轮每转所代表的转台度数 Rotating angle of table with one revolution of the worm	3°	2°	2°
游标最小示值 Minimum value of vernier	10"	10"	10"
分度精度 Indexing accuracy	30"	30"	30"
工作台最大承载 Max. workload kg	5500	8500	10000
净重 Net weight Kg		7500	
毛重 Gross weight Kg			
箱体尺寸 Case dimensions mm			

1001-0160...1250, 1001 (TS) 系列回转工作台
1001-0160...1250,1001(TS) SERIES ROTARY TABLE

1001-0160...1250,1001(TS)系列回转工作台安装尺寸图 Dimensional Sketch

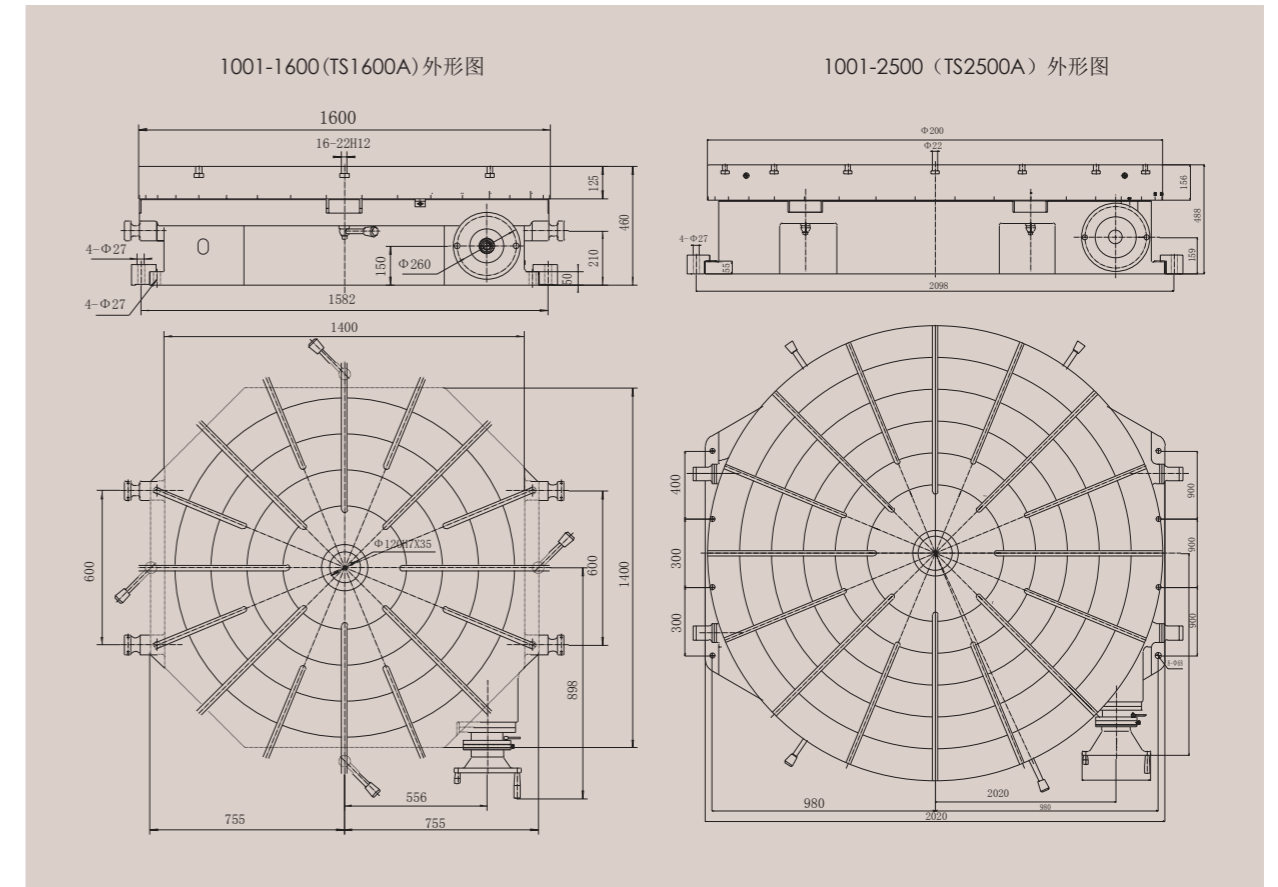

HITECH (Qingdao)
ENTERPRISES INC